







Current Consumption Analysis of LCD and AMOLED Display Technologies: An Approach Based on Multi-Text Input Modalities

Jussif Abularach Arnez , Rafael M. Ribeiro , Janisley O. De Sousa ,
Maria Gabriela Lima Damasceno , Bruno S. Da Silva , and Gidy C. F. Navarro 

Abstract—When evaluating battery consumption in mobile devices in the fifth-generation (5G) network, it's crucial to consider the display technology used, as different technologies consume varying amounts of energy. Liquid Crystal Display (LCD) and Dynamic Active Matrix Organic Light-Emitting Diode (AMOLED) are two prevalent display technologies. LCD is an older technology that remains widely used due to its affordability and widespread availability. On the other hand, Dynamic AMOLED is a more advanced display technology in modern smartphones. Typing on a keyboard, swiping through screens, and using voice commands consume different amounts of power. This paper aims to analyze the current consumption of display technologies baseline conditions (idle, light/dark, white/black screens) and during text entry using three input modalities (type, swipe, and speech) with 79 and 202 characters. A comparative analysis was conducted between smartphones equipped with LCD and Dynamic AMOLED displays. The results demonstrated that Dynamic AMOLED technology consistently saved energy, achieving reductions of up to approximately 40% in specific modes (e.g., dark/standby or reading-like conditions). In contrast, Plane-to-Line Switching (PLS) LCD has around 30% higher average current consumption than Dynamic AMOLED. Dynamic AMOLED offers notable advantages in energy savings under specific modes. Understanding the distinctions between display technologies and input modalities enables software application developers, electronic manufacturers, and users of 5G mobile devices to make informed decisions regarding smartphone selection and usage patterns.

Link to graphical and video abstracts, and to code:
<https://latam.ieeer9.org/index.php/transactions/article/view/9997>

Index Terms—Power consumption, Display, LCD, AMOLED, Text Input.

I. INTRODUCTION

The associate editor coordinating the review of this manuscript and approving it for publication was Roberto S. Murphy (*Corresponding author: Jussif Abularach Arnez*).

This work was presented as part of the results of the Project SIDIA-M_Model_Advanced_Mobile_Networks_Devices (AMAN), carried out by the Institute of Science and Technology - SIDIA, in partnership with Samsung Eletrônica da Amazônia LTDA, according to Informatics Law n.8387/91 and Art. 39 of Decree 10.521/2020.

Jussif Abularach Arnez, R. M. Ribeiro, J. O. D. Sousa, M. G. L. Damasceno, B. S. D. Silva, and G. C. F. Navarro are with Sidia Institute of Science and Technology, Manaus, Brazil (e-mails: jussif.arnez@sidia.com, rafael.ribeiro@sidia.com, janisley.sousa@sidia.com, maria.lima@sidia.com, bruno.satiro@sidia.com, and gidynavarro@sidia.com). Bruno and Gidy were former employees at Sidia and can be reached at brunosatiro.g5@gmail.com, and gflorezn@gmail.com, respectively).

MOBILE devices like smartphones have grown steadily over the past two decades. By the end of 2024, the total number of active mobile devices is estimated to be over 17.7 billion. As mobile communications systems evolve, new features and updates are added to devices to optimize the user experience. However, the more features are added, the greater the battery consumption. Therefore, strategies and technologies that reduce current consumption have become crucial in the design of mobile devices. A key point in the user's Quality of Experience (QoE) is the display, which has evolved in parallel with the advancement of the electronics industry. One of the main issues in developing new technologies aimed at screens is their energy efficiency since the display is one of the constituent parts of a smartphone that most drains battery power [1], [2]. Various display technologies have been developed and employed in the mobile device industry. A primary display technology is the Liquid Crystal Display (LCD) [3], which has transparent liquid crystals that alter their molecular structure when they receive an electric current, causing the colors to appear on the display. LCD screens are not energy efficient because a light layer is always on. Over time, improvements have emerged for LCD screens, for instance, In-Plane Switching (IPS) [3], [4] technology, which promotes a parallel grouping of crystals, allowing a better viewing angle and brighter colors.

Through technological advances, Light Emitter Diode (LED) [3] technology has been applied to screens, which use light-emitting diodes instead of liquid crystals. The evolution in the application of this technology in displays occurred when manufacturers began to insert a series of thin layers of organic material between one conductor and another. These layers help preserve electrical current, promoting a higher contrast ratio and significant energy savings. From this method comes the name Organic Light Emitting Diode (OLED) [3]. An OLED variation is Active Matrix Organic Light Emitting Diodes (AMOLED) [3], which utilizes an active matrix to individually control each pixel on the display, resulting in enhanced image quality and reduced current consumption compared to conventional OLED displays. Samsung has developed an improved AMOLED technology, Super AMOLED, which combines the active matrix of AMOLED with a capacitive sensor layer, allowing the display to function as a touch panel. Super AMOLED displays provide more accurate colors, reduced thickness, and increased energy savings compared to conventional AMOLED technology.

This research investigates the current consumption of display technologies—specifically Liquid Crystal Displays (LCD) and Dynamic AMOLED—in mobile devices operating within Fifth-Generation (5G) networks. Addressing the critical need for optimized battery performance in modern smartphones, this study systematically compares the power demands of these prevalent display technologies under various baseline scenarios and in relation to different text input methods.

Understanding these differences is crucial for end-users seeking to maximize device usability and manufacturers striving to enhance product appeal through improved energy efficiency. The main contributions of this paper are as follows:

- A power profiling methodology to isolate display technology scenarios of usage, using standardized conditions.
- A comprehensive cross-technology assessment of PLS LCD vs. Dynamic AMOLED across baseline states and multi-text input modalities.

The present work is divided into four sections. Section II discusses the related works, their limitations and contributions, and how they can be used as references for our study. Section III explains concepts considered in this work. Section IV describes the investigation’s methodology process, while Section V presents and analyzes the findings. Finally, Section VII and VI summarize the results, providing insights into the results and identifying areas for future investigation, respectively.

II. RELATED WORKS

Prior studies have examined how text-entry techniques and usage contexts influence user performance and energy behavior. The impact of how the messages are inputted on mobile phones is important regarding the need to recharge the battery. In [5], T9 and QWERTY were compared across indoor/outdoor and sit/walk scenarios, reporting words-per-minute, error rates, and physiological responses. While informative for ergonomics and usability, that work did not report direct power metrics. The analysis primarily compared the words per minute a user types on the smartphone and extracted error rates based on input posture. Additionally, the study includes physiological reactions measured from each user depending on the scenario and concludes that an effective input depends on the scenario (type of text).

Touch-interaction characteristics and affect were explored in [6], which compared tapping and Swype and inferred emotions via a machine learning model using features such as typing speed, touch pressure, and errors. Touch-based emotion detection was investigated, a machine learning (ML) model where user emotion was inferred, a study with the collected data, and a designed application that measures different parameters related to tracing users’ text entry activities was displayed. The authors compared related works using different touch modalities with their emotion detection application. Features such as typing speed, touch pressure, and error rate from touch interactions were obtained and then correlated with reported emotion labels to develop the ML model.

Display-side energy modeling has also been investigated. In [7], the authors analyze the current consumption by the essential elements of the interface and the primary color palette

on Thin-Film-Transistor (TFT) displays, where the data on the current consumption of the mobile device were evaluated from a theoretical point of view and a mathematical model of the battery consumption of the mobile device was compiled. A survey presented in [8] dealt with the latest research and advancements on the power saving and optimization of OLED displays, which are very popular among current system designs due to various advantages like picture quality, response time, lightweight, and lower thickness. Nevertheless, although many methods are available to reduce current consumption, such as lowering the refresh rate, panel self-refresh, or adaptive dimming, designers are still looking for better optimization.

Regarding input modalities, [9] reported that soft keyboards are generally more energy-efficient for short texts, whereas speech-to-text can be advantageous for longer inputs (noting the impact of network processing in earlier-generation systems). The authors analyzed three text input modalities: soft keyboard (SK), speech-to-text (STT), and Swype. The results showed that the most efficient form of input in terms of battery consumption was, according to the text size, i.e., if the interaction was short, on average less than 30 characters, using the device SK was the most energy efficient. Using an STT application was more energy efficient for extended interactions. Swype was more energy efficient than STT for very short interactions, with less than 5 characters on average, but was never as efficient as SK. Our work uses a methodology based on the abovementioned paper to analyze two display technologies concerning text input mode, comparing LCD and Dynamic AMOLED battery consumption.

Ghaffar *et al.* [10] introduced eFairWrite, a novel air-writing gesture input method aimed at reducing energy consumption for text entry in wearable and Augmented Reality (AR) and Virtual Reality (VR) devices. The system captures free-hand writing motions through wearable sensors, processing them locally to minimize reliance on high-power displays. Experimental evaluation compared eFairWrite to virtual keyboards and voice input across everyday text-entry tasks. Results showed substantially lower energy consumption per character without significant drops in accuracy.

This study [11] evaluated light emission parameters from smartphone LCDs released over the past decade using advanced photometric and colorimetric methods. Despite technological progress, visible radiation characteristics changed little. Improvements were found in viewing angles and sRGB compliance. Built-in blue light filters had minimal effect, while third-party apps were more effective but also reduced overall brightness and color temperature. Power-saving modes reduced refresh rates but did not affect flicker depth or static contrast. The results highlight the need for further development of display technologies that support user health. On the other hand, a recent study [12] compared LCD, OLED, and MicroLED display technologies in terms of structure, operation, manufacturing, contrast ratio, and viewing angles. LCDs are cost-effective but limited in contrast and viewing angles. OLEDs offer high contrast and flexibility but face aging and lifespan issues. MicroLEDs provide high brightness and wide viewing angles but are currently constrained by high production costs. The analysis highlights each technology’s

TABLE I
COMPARISON OF RELATED WORKS

Reference	Objectives	Methods	Limitation	Contributions
[5]	Compare T9 and QWERTY text input methods based on user scenarios and performance.	Analyzed words per minute, error rates, and physiological reactions in indoor/outdoor and sitting/walking scenarios.	Limited to specific scenarios and postures; may not generalize to all user contexts. Results are specific to the tested device and keyboards (T9 is now less common). No direct power metrics.	Explores how text input modality (on-screen QWERTY keyboards vs T9 keypad), user posture. Provided insights into how input methods and scenarios affect typing speed and error rates.
[6]	Investigate touch-based emotion detection using Swype and basic tapping methods.	Developed a machine learning model to infer emotions from typing speed, touch pressure, and error rates.	It relies on self-reported emotion labels and may not capture all emotional nuances. Only two input modalities (tapping and swiping).	Introduced a novel approach to emotion detection through touch interactions and compared it with existing methods.
[7]	Analyze the current consumption of Thin-Film-Transistor (TFT) displays based on interface elements and color palettes. This work improves understanding of power usage at the UI level, e.g., how much energy a particular icon or color scheme costs. Survey advancements in power-saving techniques for OLED displays. Presents a comprehensive survey of techniques to reduce the current consumption of OLED displays on battery-powered devices.	Compiled a mathematical model of battery consumption in TFT displays.	Theoretical analysis lacks real-world testing or validation. The measurements were done using the phone's internal sensors, which introduces some measurement error.	Provided a theoretical framework for understanding battery consumption in TFT displays. Empirical measurement (on-device sensors).
[8]	Compare the battery efficiency of soft keyboard (SK), speech-to-text (STT), and Swype for different text sizes to recommend the most energy-efficient way to enter text under different conditions.	Reviewed methods like refresh rate reduction, panel self-refresh, and adaptive dimming.	Focused on existing methods; does not propose new solutions. It synthesizes existing literature.	Highlighted current trends and challenges in OLED display optimization for energy efficiency.
[9]	Introduce an air-writing gesture input technique optimized for low energy use in wearable or Augmented Reality (AR) devices. The method aims to reduce display and device power when entering text by writing in the air (gesture) instead of using the on-screen User Interface (UI).	Analyzed battery consumption for short, medium, and long text inputs. Input modalities: touchscreen keyboard typing vs Speech-to-text vs Swipe-gesture typing.	Limited to specific text sizes; may not cover all use cases. The findings were based on 2015-era technology, e.g., the energy cost of voice input included network usage for STT, which may have changed with newer on-device speech.	SK was the most energy-efficient method for short interactions, and STT was the most energy-efficient method for longer ones.
[10]	Evaluate smartphone displays' qualitative/quantitative light-emission parameters over the last decade, emphasizing user health impacts.	A prototype wearable that captures handwriting motions in the air and processes them on-device (edge computing) to avoid using a high-power display. They also measured power consumption compared to conventional methods like voice or on-screen typing.	It requires a special wearable sensor and calibration, not yet a default smartphone capability, for short interactions; the overhead of starting the sensor might offset savings.	Demonstrated an input modality that yields lower energy per character in AR settings. It preserves battery life by offloading recognition to the wearable and minimizing screen usage.
[11]	Compare LCD, OLED, and MicroLED technologies across structure, operation, manufacturing, contrast ratio, and viewing angles to assess suitability and future directions.	Advanced photometric/colorimetric instrumentation measuring gamut, RGB linearity, SPD, refresh/flicker, luminance, uniformity, static contrast; tests of built-in and app-based blue-light filters and power-saving modes.	Small sample (n=9); optics-focused (no device-level current); variability across third-party apps; health effects inferred, not longitudinally measured.	Finds marginal changes in visible-radiation parameters across years; improved viewing angles and sRGB compliance; AMOLED gamut ~140-150% sRGB; power-saving reduces refresh rate with little change to flicker depth or static contrast; calls for health-aware display design.
[12]	Analyze the current consumption in LCD and Dynamic AMOLED display technologies.	Literature-based comparative analysis and technology survey (qualitative).	No device-level measurements or energy profiling; MicroLED cost/scale evolving; high-level by design.	Clarifies strengths/limits: LCD is cost-effective but has limited contrast/angles; OLED has high contrast/flexibility with aging/lifespan issues; MicroLED has high brightness/angles but high manufacturing cost; guidance on application domains and roadmap.
This work	Evaluation of Sleep and Idle modes, Black Screen, White Screen, and Touch Screen for different numbers of characters.	Evaluation of Sleep and Idle modes, Black Screen, White Screen, and Touch Screen for different numbers of characters.	Limited to a specific number of character sizes; may not cover all use cases.	Evaluation of the Current Consumption of two typical smartphone display technologies using sophisticated equipment, i.e., Monsoon Power Monitor (MPM), to collect current consumption.

strengths and limitations, offering insights into their suitability for applications and future development directions.

Beyond interaction and energy modeling, recent works analyze display optics and technology trends. Piechota *et al.* [11] conducted a longitudinal photometric and colorimetric evaluation of smartphone LCDs from the past decade and found minor changes in visible radiation characteristics, with improvements mainly in viewing angles and sRGB compliance. Built-in blue-light filters exhibited limited effectiveness, whereas third-party filters were more effective but reduced overall brightness and shifted color temperature; power-saving modes lowered refresh rates but did not materially affect flicker depth or static contrast, underscoring the need for further display developments that consider user health. Complementarily, Jin *et al.* [12] compared LCD, OLED, and MicroLED across structure, operation, manufacturing constraints, contrast, and viewing angles: LCDs remain cost-effective yet limited in comparison and angles; OLEDs deliver high contrast and flexibility but face aging/lifespan concerns; MicroLEDs promise high brightness and wide angles but are currently constrained by production cost. These optical and technology-landscape findings contextualize our focus on in-situ electrical behavior: unlike [11], [12], we provide controlled, device-level current measurements that isolate the energy implications of display technology (PLS LCD vs. Dynamic AMOLED) under baseline states and cross-modality (type, swipe, speech) evaluations using power consumption profiling under baseline states and different message lengths. Table I compares the objectives, methodology, limitations, and contributions of the related works.

TABLE II
COMPARISON OF DISPLAY TECHNOLOGIES

Feature	Dynamic AMOLED	PLS LCD
Developer / Origin	Samsung (advanced form of AMOLED)	Samsung (alternative to IPS LCD)
Display Type	Self-emissive (each pixel emits its own light)	Backlit (requires LED backlight)
Current Consumption	Lower, especially with dark themes	Higher due to always-on backlight, regardless of image content
Black Level	True blacks (pixels turned off = zero light)	Greyish blacks (backlight leakage)
Color Gamut & Saturation	Very wide (DCI-P3, HDR10+, vivid colors)	Standard sRGB or NTSC, less vivid
Durability	More prone to burn-in (static images)	No burn-in; more durable under static usage
Environmental Efficiency	Better with dark UIs and energy-conscious design	Constant backlight, less dynamic energy profile
Touch Sensitivity	Integrated touch layer (on-cell)	Usually separate touch layer

III. BACKGROUND

PLS LCD technology improves viewing angles and color accuracy over traditional LCDs. The principal layers are explained as follows [3], [13]–[15]: The Cover Glass serves as a protective layer that shields the display from physical damage. Above it, the Top Polarizer controls light reflection and glare.

The Glass Substrate with TFTs houses thin-film transistors that control pixel illumination, while the Liquid Crystal Layer modulates light to create images by adjusting the orientation of liquid crystals. The Color Filter applies red, green, and blue colors to pixels, and the Bottom Glass Substrate supports the liquid crystal layer. Below this, the Bottom Polarizer further controls light transmission and enhances contrast. Finally, the Backlight Unit (BLU) provides consistent illumination across the screen. Unlike Dynamic AMOLED, PLS LCDs require a backlight, which can lead to higher current consumption and less contrast in dark images. However, they are generally more cost-effective and perform well in well-lit environments.

Dynamic AMOLED technology is a self-emissive display, where each pixel emits its own light. This structure allows for deeper blacks and higher contrast ratios. The principal layers are explained as follows [3], [15]–[18]: The Cover Glass serves as a protective layer that shields the display from physical damage. Integrated above it is the Touch Sensor, an on-cell touch layer that detects user interactions. The Polarizer reduces glare and reflections, enhancing visibility, while the Encapsulation Layer provides thin-film encapsulation (TFE) to protect organic layers from moisture and oxygen. Below these layers, the Cathode, typically a thin metal layer such as aluminum, injects electrons into the emissive layer. The Emissive Layer, composed of organic compounds, emits light when energized. The Conductive Layer transports holes from the anode to the emissive layer, and the Anode, a transparent layer like indium tin oxide, injects holes into the conductive layer. The TFT Backplane, consisting of thin-film transistors, controls the current to each pixel, while the Substrate serves as a flexible or rigid base that supports the TFTs and organic layers. This configuration eliminates the need for a backlight, resulting in thinner displays with better energy efficiency, especially when displaying darker images. Fig. 1 shows the structure layers of the Dynamic AMOLED display.

AMOLEDs [3] offer significant advantages over traditional OLEDs [3], [18], particularly in terms of response time and energy efficiency. By incorporating a thin-film transistor (TFT) array, AMOLED displays achieve much faster response times, making them especially suitable for applications that require rapid image changes, such as video playback and gaming. Furthermore, their lower current consumption enhances this performance. The TFT array allows for direct control of individual pixels, which reduces dependence on external circuitry and minimizes power usage. As a result, AMOLED technology improves visual experiences with better refresh rates and contributes to energy savings, making it an appealing choice for large-scale display applications. In an AMOLED display, an electric current flows through the organic layer. This current causes the organic materials to emit light independently. This results in faster response times, reduced motion blur, and superior contrast ratios, especially in darker images, while eliminating the need for a backlight and enhancing energy efficiency [16], [17].

Dynamic AMOLED is an advanced version of this technology that improves visual performance with deeper blacks and more vibrant colors through enhanced contrast ratios and color accuracy. Plane-to-Line Switching (PLS) [3], [15] is an

LCD technology to improve traditional TFT and rival IPS panels. It offers wide viewing angles, good color accuracy, and enhanced brightness. While not as energy-efficient as OLED technologies, PLS displays are durable, less prone to pressure marks, and cost-effective, making them suitable for mid-range smartphones and tablets. Fig. 1 presents the displays' layer structures. In addition, Table II compares essential PLS LCD and Dynamic AMOLED technologies' characteristics and features.

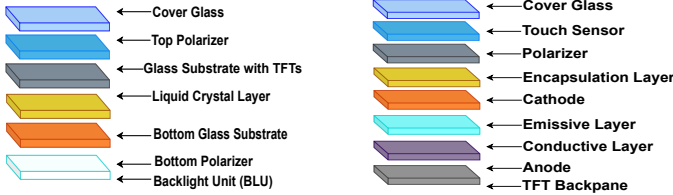

Fig. 1. Left) PLS LCD Displays' Structure Layers; Right) Dynamic AMOLED Displays' Structure Layers.

IV. METHODOLOGY

This section details the experimental methodology design used to compare display technologies under controlled conditions. First, Subsection IV-A describes the instrumentation to measure the current consumption during the experiments and device technology specifications. Finally, Subsection IV-B specifies the twelve test scenarios, the interactive workloads (typing, swiping, speech-to-text) at two message lengths used to elicit display activity in realistic usage.

A. Data Collection

The Power monitor supplied power and logged current via the PowerTool Automation API. At the same time, the DuT communicated over USB for scenario control, which allows graphical visualization of data in real-time execution. The experiments were conducted with Airplane mode enabled. Fig. 2 illustrates the experimental setup. We employed a non-invasive method to measure current consumption using the bypass mode method [19]. This approach requires no hardware modifications to the measurement circuit. A transistor is activated within the charger IC driver to manage the energy from the battery. At the same time, Overvoltage Protection (OVP) and Adaptive Input Current Level (AICL) are enabled to ensure safety. The testbed scenarios include measurements of sleep current over 20 seconds, idle current over 60 seconds, and black and white screen currents recorded over 60 seconds each. All scenarios were measured thrice (Test 1, Test 2, and Test 3). These data points provide insights into the device's current consumption under various states. We captured the whole interaction for text-entry and computed the average current over the entry interval. In this context, the measurements were conducted as follows:

- 1) Set the bypass of the smartphone's battery;
- 2) Direct Connection of the MPM to provide energy to the DuT's battery;
- 3) Configuring the scenario on the local host;

- 4) Measurement and collection of data in 3 consecutive rows for each scenario;
- 5) Analysis peak current consumption;
- 6) Computing the average current consumption.

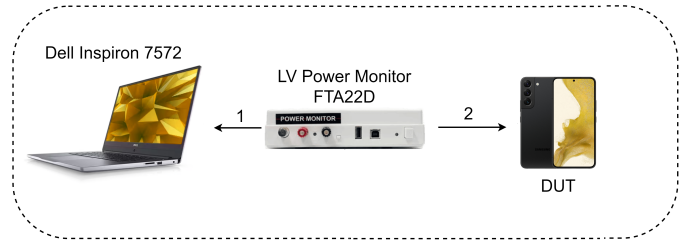

Fig. 2. High-Level Configuration of the Display Power Consumption Measurements Testbed.

The proposed scenarios intend to verify the difference in current consumption concerning various user-text-input modalities: swiping, typing, and speech-to-text (talking). For each modality, 79 and 202 characters were considered. These scenarios were designed based on reference research studies [9], [20] to analyze the impact of power consumption across multi-text input modalities. Based on results from these studies, the significant current consumption impacts were identified in 79 and 202 characters modalities. Therefore, this study focuses on analyzing the impact of type, swipe, and talk over the PLS LCD and Dynamic AMOLED technologies.

In addition, the current consumption of the smartphone's screen in light and dark modes was evaluated. The current consumption of white and dark screens was also analyzed. Table IV summarizes the 11 scenarios evaluated in this work. It provides a detailed overview of each scenario's conditions and parameters (input method, number of characters, and time) considered. The Table III, on the other hand, presents the characteristics and specifications of the two DuTs. It highlights the key hardware differences and similarities between the two devices.

B. Scenario Analysis

There were 12 scenarios assessed in total, keeping the same Device under Test (DuT) usage conditions and measuring current consumption, which were then compared. The measurements were done using the Monsoon Power Monitor (MPM) [19], a local host, and two DuTs, as shown in Fig.2. The MPM equipment is responsible for monitoring the smartphone's current consumption and providing energy to the smartphone once the bypass mode is on.

Tests were conducted to analyze current consumption by repeating each test three times. The battery consumption test benches were configured as seen in Table IV. Firstly, the battery consumption was measured under various conditions without human interaction. This approach provided a baseline for the consumption approach. After obtaining these results, we utilized various input methods to extract current consumption values during the user interactions.

For an accurate current consumption analysis, the following services were disabled on the smartphones: Wi-Fi, Bluetooth, Location services, NFC, Double AP, Always-On Display

TABLE III
COMPARISON OF DUT HARDWARE SPECIFICATION

Feature	SM-S918B (Galaxy S23 Ultra)	SM-A146M (Galaxy A14 5G)
Manufacturer	Samsung	Samsung
Device Type	High-end Flagship	Mid-range
Processor	Qualcomm Snapdragon 8 Gen 2 for Galaxy (Octa-core)	Exynos 1330 (Octa-core)
GPU Graphics Processing Unit	Qualcomm Adreno 740	ARM Mali-G68 MC4
Memory (RAM)	8GB / 12GB LPDDR5X	4GB (with RAM Plus)
Internal Storage	256GB / 512GB (UFS 4.0)	64GB / 128GB
Display Type	6.8-inch Dynamic AMOLED 2X, 120Hz	6.6-inch PLS LCD Infinity-V, 90Hz
Display Resolution	1440 x 3088 pixels (120Hz, HDR10+)	1080 x 2408 pixels (90Hz)
Screen-to-body-ratio	≈ 80.2(%)	≈ 89.9(%)
PPI Density	≈ 400	≈ 500
Display Protection	Gorilla Glass Victus 2	N/A
Rear Camera	Quad-camera system: 200MP (Main), 10MP (Periscope Telephoto), 10MP (Telephoto), 12MP (Ultrawide)	Triple-camera system: 50MP (Main), 2MP (Macro), 2MP (Depth)
Front Camera	12 Megapixels	13 Megapixels
S-Pen Support	Integrated with Bluetooth functionality	No support
Battery Capacity	5000 mAh	5000 mAh
Charging	45W wired, 15W wireless, 4.5W reverse wireless	15W wired
Operating System	Android 15	Android 15
Connectivity	5G, Wi-Fi 6E, Bluetooth 5.3, NFC, GPS	5G, Wi-Fi 5, Bluetooth 5.2, GPS
Dual-SIM Support	Yes (Dual physical or physical + eSIM)	Yes
Audio	No headphone jack	3.5mm headphone jack
Launch Year	2023	2023

(AOD), Always-On Touch (AOT), Motions and Gestures, Advanced Features, Auto Sync Data, Automatic Rotation, S-Pen, Memo and Quick Create Notes, and Accidental Touch Protection. The devices were also set to maximum brightness in both dark and light modes to demonstrate the differences in current consumption. This maximum brightness was also used to facilitate proper device usage. Each device was placed on a testing bench and evaluated under various conditions, including Sleep, Idle, Black Screen, White Screen, and Touch Screen. As indicated in Table IV, only two character limits were tested: 79 and 202 characters. These amounts were selected to illustrate the differences in current consumption when using the Touch, Swipe, and Talk text input options. When utilizing the Touch feature, user interaction involves clicking on the screen, which consumes power with each touch. In contrast, Swipe consists in sliding a finger across the screen.

To isolate the effect of display technology, we controlled for smartphones, environment, software, and workload factors known to confound power measurements:

- 1) *Power Supply*: Because battery voltage varies with state-of-charge and load, we fix the external supply at a constant output (e.g., 4.50 V) and report *power* alongside current (mA). This avoids over-attributing differences to

current alone.

- 2) *Luminance and colorimetric calibration*: Panel brightness was standardized to a target photometric luminance (e.g., 200 cd/m² at D65 white). We lock the display color mode to sRGB, fix the white point (D65), and use the same gamma/EOTF across devices.
- 3) *Refresh and driver behavior*: Variable refresh, always on display and motion smoothing are disabled; refresh rate is fixed (e.g., 60 Hz) for all baseline and interaction scenarios. HDR, tone mapping, and adaptive color features are off.
- 4) *Software state and background load*: Beyond disabling Wi-Fi, Bluetooth, location, NFC, AOD/AOT, gestures, auto-sync, auto-rotate, S-Pen features, and accidental-touch protection, we also: enable airplane mode; disable haptics, audio feedback, and vibration; run in Safe Mode (where feasible) to suppress third-party services; clear recent and boot fresh between blocks; fix CPU/GPU governors to default balanced policies (no over/under-clocking); and log CPU/GPU utilization and frame times during interactions to verify comparable non-display load.
- 5) *Environmental and thermal control*: Tests are performed in a controlled ambient (e.g., 23 ± 2°C, RH 40–60%). Devices are preconditioned to thermal steady state; we monitor skin temperature and SoC-reported die temperature. Runs are randomized and separated by cool-down intervals to avoid order and thermal drift effects.

TABLE IV
CONFIGURATIONS SCENARIOS AND MULTI-TEXT INPUT MODALITIES

#	Scenario	Input Method	Number of Characters	Time (s)
1	Home Screen (light mode)	NaN	NaN	60
2	Home Screen (dark mode)	NaN	NaN	60
3	White Screen ¹	NaN	NaN	60
4	Dark Screen ²	NaN	NaN	60
5	Screen Off	NaN	NaN	60
6	Text Input 1	Type	79	NaN
7	Text Input 2	Type	202	NaN
8	Text Input 3	Swipe	79	NaN
9	Text Input 4	Swipe	202	NaN
10	Text Input 5	Talk	79	NaN
11	Text Input 6	Talk	202	NaN

¹ Hardware diagnostic menu by typing *#0*# and selecting White.

² Hardware diagnostic menu by typing *#0*# and selecting Dark.

C. Power Consumption Analysis

We employed a non-invasive method to measure current consumption using the switch mode method [19]. This approach requires no hardware modifications to the measurement circuit. A transistor is activated within the charger IC driver to manage the energy from the battery. At the same time, Overvoltage Protection (OVP) and Adaptive Input Current Level (AICL) are enabled to ensure safety. Fig. 3 illustrates how the switch mode method operates by controlling the charger and PMIC circuits within the smartphone. Additionally, the non-invasive approach bypassed the battery and

directly manipulated the Metal-Oxide-Semiconductor Field-Effect Transistor (MOSFET) within the Power Management Integrated Circuit (PMIC). This allowed for precise power consumption measurements without disrupting the device's standard functionality. The Charger IC directly powered the smartphone via Vbus with MPM, bypassing the battery connection. In this configuration, the PMIC solely distributes the energy required by the hardware components.

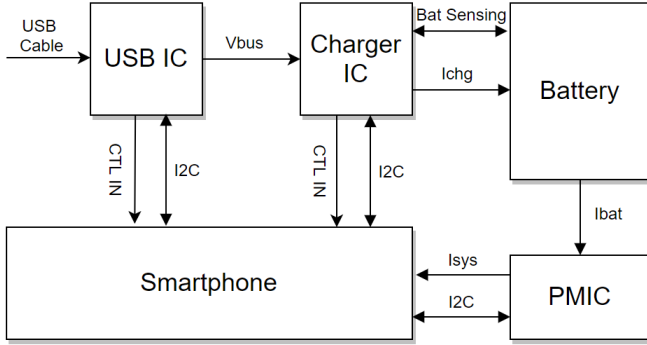

Fig. 3. Switch Mode Method employed to Bypass the PMIC and utilize Energy exclusively from the MPM.

This methodology allowed for precise and reliable analysis of how different input methods influence energy efficiency. The implementation is divided into two parts within the Android OS stack:

- In the kernel space, we provide a Linux kernel device driver implementation for the power measurement method.
- In the user space, when a USB cable is attached to the smartphone and connected to the power monitor, battery switch mode is enabled via the Random Access Memory (RAM)-based filesystem, a.k.a. sysfs kernel interface.

Fig. 4 illustrates the methodology for isolating and measuring the power consumption of display technologies in a controlled environment. By employing a reference measurement in airplane mode to measure the sleep mode current (C), the current consumption of the device under test (DuT) is isolated. The aggregate power consumption of the operating system and hardware components (e.g., CPU, memory, GPU, network, etc.) is calculated for both scenarios: when the device is with the LCD on (A) and in idle mode (B). This value is then subtracted from the total power consumption to isolate and quantify the display technology's power consumption.

To accurately assess the impact of various input modalities on power consumption, this study meticulously controlled for factors such as user interaction styles and usage contexts. By terminating all background processes on the smartphone, except for the application used in the experiment, and maintaining a constant screen brightness, the research ensured that power usage was solely attributable to user inputs. To isolate the effect of display technology, we controlled for smartphones, environment, software, and workload factors known to confound power measurements:

- 1) *Power Supply*: Because battery voltage varies with state-of-charge and load, we fix the external supply at a

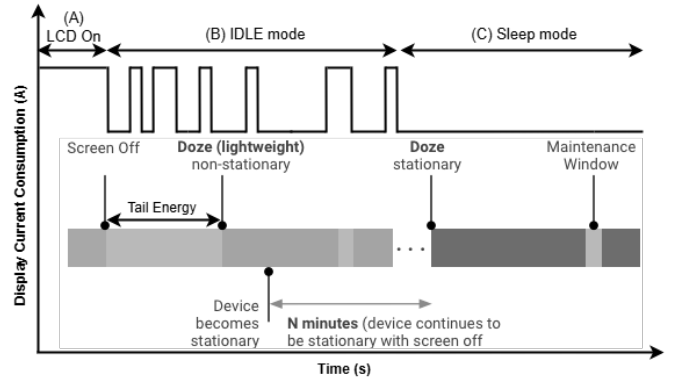

Fig. 4. Controlled scenario designed to measure display power consumption in the Android Operating System.

constant output (e.g., 4.50 V) and report *power* alongside current (mA). This avoids over-attributing differences to current alone.

- 2) *Luminance and colorimetric calibration*: Panel brightness was standardized to a target photometric luminance (e.g., 200 cd/m² at D65 white). We lock the display color mode to sRGB, fix the white point (D65), and use the same gamma/EOTF across devices.
- 3) *Refresh and driver behavior*: Variable refresh, always on display, and motion smoothing are disabled; refresh rate is fixed (e.g., 60 Hz) for all baseline and interaction scenarios. High Dynamic Range (HDR), tone mapping, and adaptive color features are off.
- 4) *Software state and background load*: Beyond disabling previews described items, we also: enable airplane mode; disable haptics, audio feedback, and vibration; run in Safe Mode (where feasible) to suppress third-party services; clear recent and boot fresh between blocks; fix CPU/GPU governors to default balanced policies (no over/under-clocking); and log CPU/GPU utilization and frame times during interactions to verify comparable non-display load.
- 5) *Environmental and thermal control*: Tests are performed in a controlled ambient (e.g., 23 ± 2°C, RH 40–60%). Devices are preconditioned to thermal steady state; we monitor skin and SoC-reported die temperatures. Runs are randomized and separated by cool-down intervals to avoid order and thermal drift effects.

Therefore, we established standardized baseline conditions (idle, light/dark, white/black screens) and applied controlled text input tasks using three modalities: typing, swiping, and speech. Current measurements were collected using external instrumentation to ensure accuracy and reproducibility. This procedure allowed us to isolate the impact of display technology and input modality on power demand, excluding other hardware factors from the mobile device, thereby providing a consistent framework for cross-technology comparison.

V. RESULTS AND DISCUSSION

This section presents the results of the current consumption analysis, structured into two parts: baseline scenarios and

text input modalities. Baseline scenarios provide an overview of display behavior under idle and controlled screen conditions, as a reference for energy demand without active user interaction. Text input modalities extend the analysis to dynamic user–device interactions, evaluating how different input methods influence display power usage. Combining these two perspectives, we capture static and interactive aspects of display-related consumption.

A. Baseline Scenarios

Baseline measurements establish a reference point for comparing PLS LCD and Dynamic AMOLED displays under controlled, non-interactive conditions. These scenarios include idle states and uniform color backgrounds (light, dark, white, and black screens), allowing us to characterize the intrinsic power profile of each technology. Such conditions isolate the display’s inherent behavior from user interaction and Android operation system workload differences, enabling consistent cross-device comparisons. In our previous work [15], we introduced a method for measuring current consumption as an initial approach, see Figs. 5 and 6. Our last study served as an initial exploration of current consumption display, focusing on raw data without conducting a detailed analysis. In this current study, we performed a thorough analysis to evaluate the current consumption of display technologies, considering different text input modalities. Two smartphone display types were compared: PLS LCD and Dynamic AMOLED, considering 79 and 202 characters. Figures below show the results for the average current consumption corresponding to scenarios 1 to 5 of Table IV. The PLS LCD technology is represented by pink and purple bars, while Dynamic AMOLED is depicted with blue and dark pink bars.

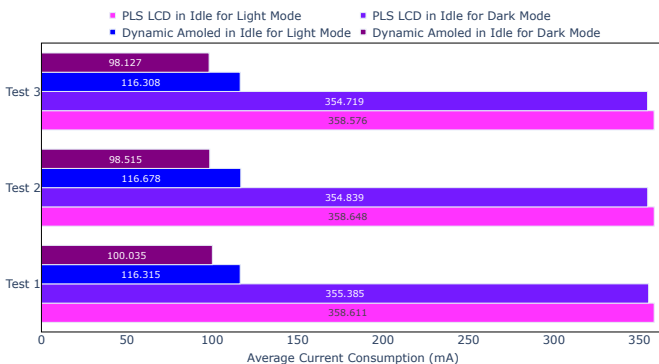

Fig. 5. Test scenarios defined to measure power consumption under Light and Dark Mode screens.

Fig. 5 illustrates the current consumption of PLS LCD and Dynamic AMOLED display technologies during the device’s Idle State under both Light (standard) and Dark Modes. In this context, the “Idle State” refers to the standby mode where the device is ready for activation but not actively displaying content. This state’s current consumption is crucial for battery life in smartphones. PLS LCD (Pink and Purple Bars), known for its performance in outdoor environments, maintains visibility under bright conditions. Its current consumption varies slightly between Dark (354.719mA) and Light (358.576mA) modes.

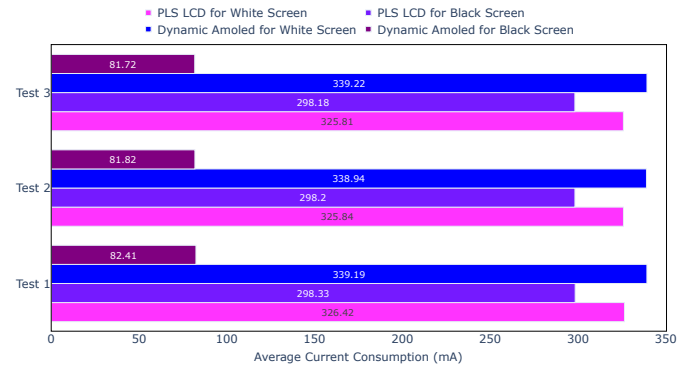

Fig. 6. Test scenarios defined to measure power consumption under White and Black screens.

On the other hand, Dynamic AMOLED (Blue and Dark Pink Bars) is an advanced technology that offers high contrast ratios and deep blacks. Its power efficiency is notable in Dark Mode due to its ability to turn off individual pixels, reducing current consumption compared to Light Mode. This comparison highlights that Dynamic AMOLED generally consumes less power in ‘Idle State,’ particularly in Dark Mode, which could benefit battery life. While efficient in certain conditions, PLS LCD may require more power management strategies in devices focusing on longevity.

Fig. 6 illustrates the current consumption in complete display configurations on white and black screens. For PLS LCD, a full white screen configuration likely consumes more power due to the need for higher backlight intensity to maintain visibility. PLS LCD may exhibit current consumption in a full black screen configuration, as only active pixels require illumination. Dynamic AMOLED might draw significant power for full white screens due to the need for all pixels to emit light, similar to PLS LCD. Dynamic AMOLED consumes less power in full black screens as its pixels can turn off completely, optimizing efficiency. Lower current consumption in black screen mode suggests potential improvements in battery life for devices using these displays. The differences in current consumption between the two technologies highlight their suitability for different applications, with PLS LCD excelling in outdoor visibility and Dynamic AMOLED offering advanced color contrast. In summary, while PLS LCD may be more power-intensive in white screen configurations, Dynamic AMOLED’s efficiency in black screens could offer advantages depending on usage scenarios.

Fig. 7 is compared when PLS LCD and Dynamic AMOLED displays are turned off. For the former, backlighting is required to display images. Even when the screen is turned off, it likely consumes power to maintain its circuitry and readiness for activation. The pink bar indicates baseline current consumption due to the need to keep the display’s state and potential additional components like sensors. The latter uses organic light-emitting diodes without a backlight. When turned off, it doesn’t supply power to its pixels, potentially leading to lower standby current consumption. This efficiency stems from its advanced technology without a backlight and its ability to entirely turn off pixels.

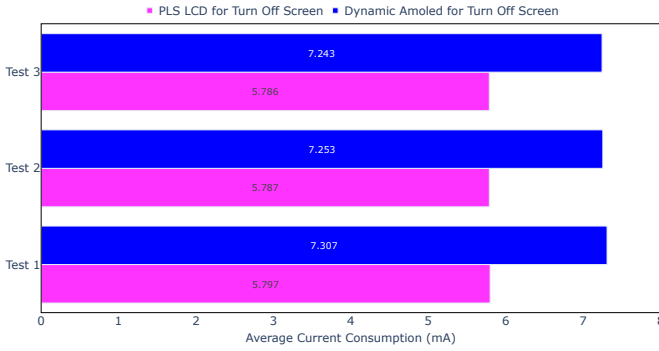

Fig. 7. Test scenarios defined to measure power consumption during Screens-Off (Sleep Mode).

Overall, Dynamic AMOLED consistently demonstrated lower current consumption compared to PLS LCD across both baseline and text input tasks. These results align with prior findings on display power optimization [8], [9], while expanding the analysis to include interaction-driven scenarios. It should be noted that residual variability, such as kernel tasks, thermal effects, or memory refresh, could not be fully eliminated. However, this variation remained below 5% of measured current and did not alter the observed trends.

B. Text Input Modalities

Text input tasks were evaluated to capture the effect of user interaction on display-related current consumption. Three modalities were tested: typing on a soft keyboard, swiping across the screen, and speech-to-text. Each task was standardized using predefined text lengths to ensure comparability between devices and input methods. This analysis links display technology with practical usage scenarios, reflecting the energy impact of everyday interactions in the smartphone.

Fig. 8 to Fig. 13 show the results for the average current consumption corresponding to scenarios 6 to 12 of Table IV. In the scenario, two users are typing 79 and 202 characters, the displays reveal distinct performance characteristics in Fig. 9 and Fig. 10. The finding involves two users with color-coded bars: User 1 (blue/purple) and User 2 (yellow/light purple). These differences likely reflect slight variations in usage patterns and specific optimizations for Dynamic AMOLED displays. Both users' results indicate that Dynamic AMOLED consistently uses less power than PLS LCD during the typing activity. On the one hand, Dynamic AMOLED technology demonstrates higher energy efficiency, particularly in scenarios involving text-heavy content. Its ability to shut off pixels displaying black or dark colors contributes to lower current consumption than PLS LCD. On the other hand, PLS LCD technology requires constant backlighting, leading to higher consistent current consumption regardless of the screen brightness. It may offer benefits in vibrant colors and certain brightness conditions but is less efficient overall. The efficiency of Dynamic AMOLED is significant for devices prioritizing battery life, such as smartphones and tablets. While PLS LCD may offer advantages in viewing angles and color accuracy, its higher current consumption makes it less ideal for

devices where battery life is a critical factor. The presented results highlight that Dynamic AMOLED outperforms PLS LCD in energy efficiency during typing activities, aligning with the general understanding of these display technologies' performance under real-world usage conditions.

Figs. 8 and 11 present a detailed comparison between PLS LCD and Dynamic AMOLED displays under a swipe-input modality method for 79 and 202 characters. PLS LCD's reliance on backlighting results in relatively consistent power use, whereas Dynamic AMOLED may adjust brightness or pixel activity, enhancing efficiency during swipe operations. The continuous movement and potential variations in screen illumination could affect current consumption differently for each technology. Dynamic AMOLED's ability to adjust colors and pixels dynamically might contribute to better efficiency, particularly under dynamic input methods like swiping. PLS LCD's fixed backlight may not offer the same level of adaptability, potentially leading to higher current consumption in specific scenarios. The findings highlight that Dynamic AMOLED consistently outperforms PLS LCD regarding energy efficiency and performance under swipe-input methods. These results underscore the importance of display technology choice for devices prioritizing battery life and efficient user interaction.

Figs. 12 and 13 show current consumption levels for each display technology during voice input. Therefore, by comparing the current consumption, we can indicate which display type performs better in terms of power efficiency. For PLS LCD, due to its constant backlight requirement, it likely consumes more power consistently. Dynamic AMOLED, on the other hand, is potentially more energy-efficient as it only illuminates necessary pixels. Nevertheless, any visual feedback during voice input might increase power usage.

Under the "talking-input" modality, Dynamic AMOLED displays demonstrate superior energy efficiency compared to PLS LCDs. This is attributed to their ability to illuminate only necessary pixels, reducing current consumption. In contrast, the PLS LCD display requires a constant backlight, leading to higher power usage. Users should consider these findings when choosing devices for tasks involving extensive voice interactions, as Dynamic AMOLED technology offers better battery performance in such scenarios.

Fig. 14 illustrates the difference in average current con-

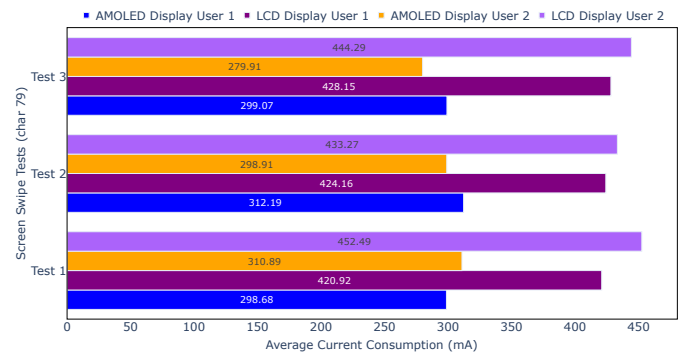

Fig. 8. Swipe-input modality method for 79 characters.

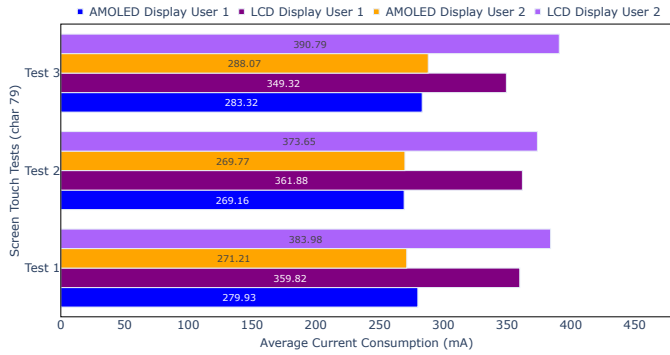

Fig. 9. Type-input modality method for 79 characters.

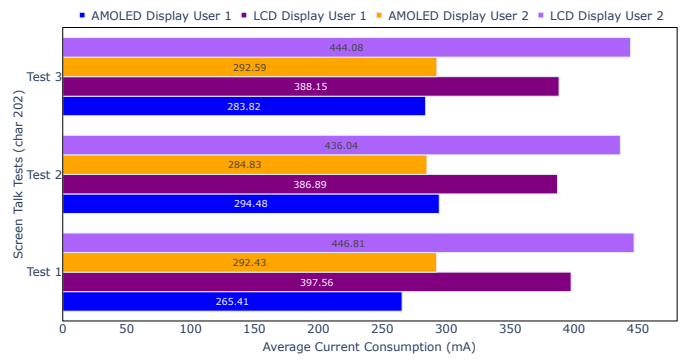

Fig. 13. Talking-input modality method for 202 characters.

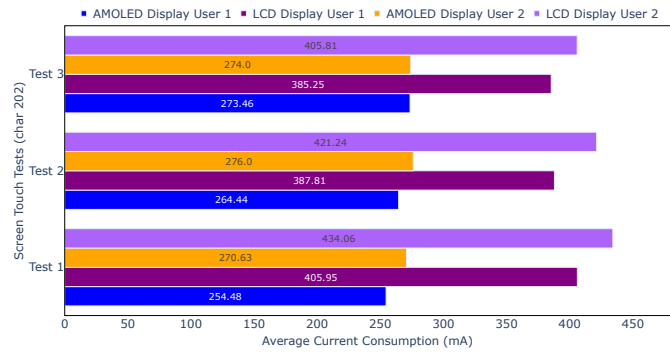

Fig. 10. Type-input modality method for 202 characters.

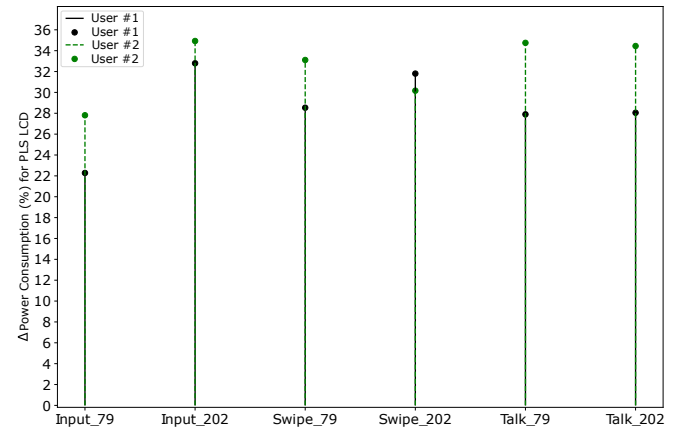

Fig. 14. Percentage Difference in Current Consumption of PLS LCD with respect to Dynamic AMOLED.

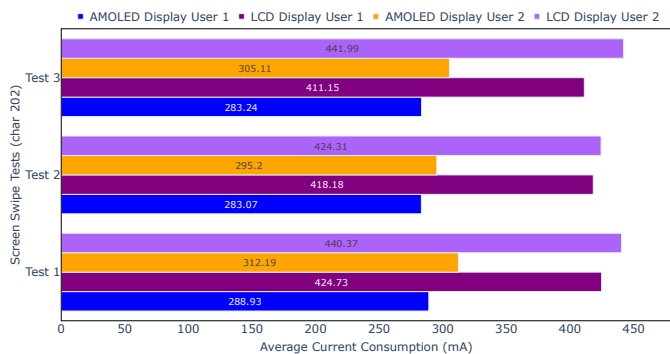

Fig. 11. Swipe-input modality method for 202 characters.

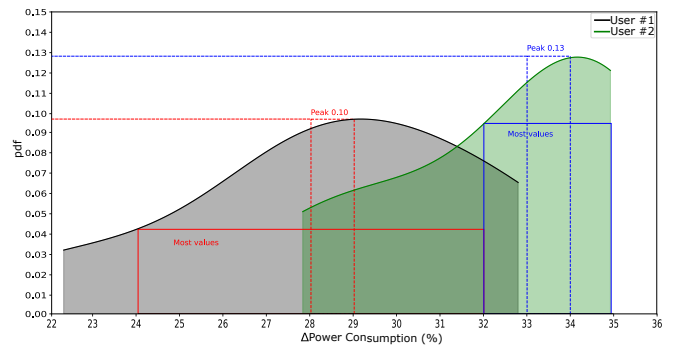

Fig. 15. PDF of the Difference in Current Consumption of PLS LCD with respect to Dynamic AMOLED.

sumption for PLS LCD and Dynamic AMOLED displays. This difference shows how high the average consumption, in

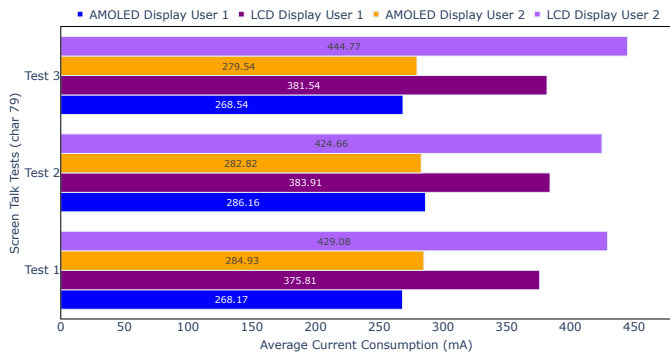

Fig. 12. Talking-input modality method for 79 characters.

percentage, is with respect to the Dynamic AMOLED display for each of the studied scenarios. Data is represented by black and green colors, corresponding to User 1 and User 2 results, respectively. PLS LCD has around 35% higher average current consumption than Dynamic AMOLED.

Fig. 15 shows an estimated probability-density function (pdf) of the difference current consumption values for User 1 (Black) and User 2 (Green). The former has a unimodal clustering around 28%–30% current consumption, the single peak, i.e., mode, where the density reaches almost 0.10. Therefore, the most frequently observed differences lie in that high-twenties range, for instance, if you randomly picked one

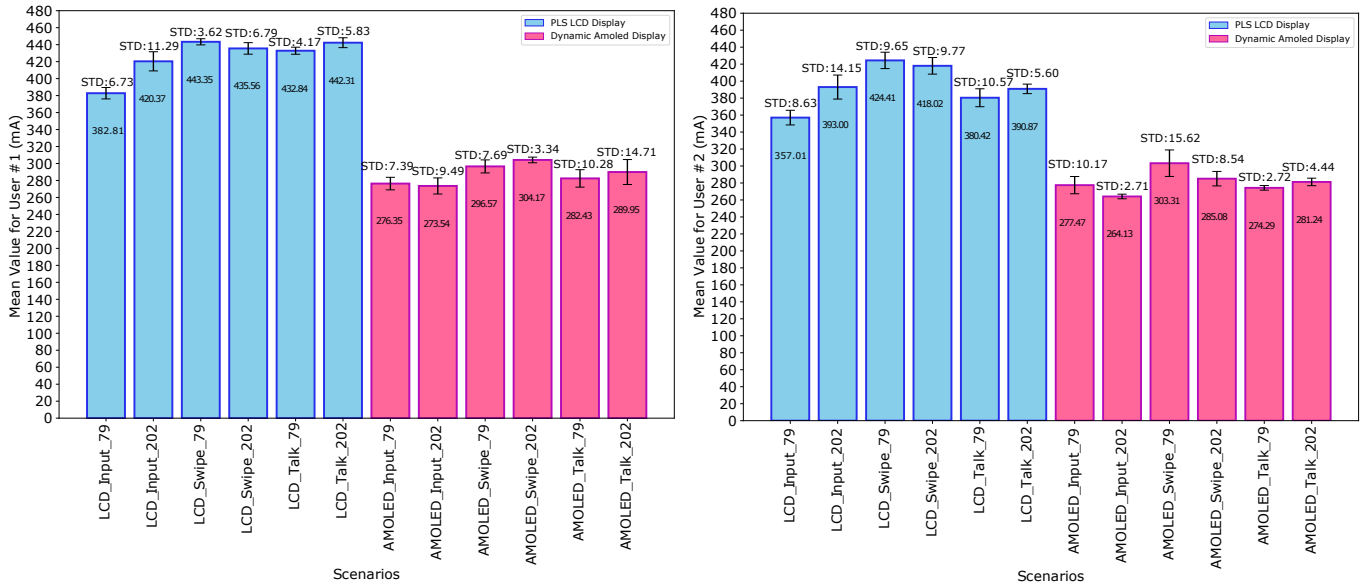

Fig. 16. Average Current Consumption for both users. Left) User 1 and right) User 2.

of the measurements of User 1, it's more likely to be near 29% than 22% or 32%. Furthermore, the density rises from near zero at 22%, climbs steadily to its peak at $\approx 29\%$, then falls back toward zero by about 32%–33%. This indicates that most values fall within a roughly 24%–32% window. The left flank (22% to 29%) is more gradual than the right flank (30% to 33%), suggesting the distribution may be mildly skewed toward lower current consumption values. In other words, values just below the mode are spread out over a broader range than those above. In this context, a pdf of ≈ 0.10 at $x=29\%$ means that in an infinitesimal neighborhood around 29%, the relative concentration of observations is highest.

On the other hand, for User 2, represented in green, there is also unimodal clustering of current consumption observed around 33% to 34%, with the mode approaching 0.13. This finding indicates that the most common recorded differences are within the high-thirties range. The density of occurrences begins at nearly zero, around 28%, steadily increasing to a peak at approximately 34%, and subsequently decreasing back toward zero by about 35%. Consequently, this analysis suggests that most values are concentrated within an interval of roughly 32% to 35%.

Fig. 16 features bar graphs that compare the current consumption mean values for user #1 and user #2 across the display types: PLS LCD and Dynamic AMOLED displays. The x-axis represents various scenarios, while the y-axis measures the current consumption mean value in milliamperes (mA). Each scenario is depicted by a pair of bars, with one bar representing each display type. The blue bars correspond to PLS LCD displays, while the pink bars illustrate Dynamic AMOLED displays. Observing the graph, it is clear that the average current consumption of PLS LCD displays consistently exceeds that of Dynamic AMOLED displays in every scenario. This difference in mean values across all scenarios indicates a significant disparity between the two display types. The standard deviation, represented by black lines above each

bar, remains relatively consistent for display types and all scenarios. This suggests that the data distribution around the mean value is similar for PLS LCD and Dynamic AMOLED displays. The graphs effectively illustrate the comparison of average current consumption between these two display technologies, highlighting their distinct characteristics in terms of mean values and standard deviations based on input types and character counts.

Across baseline states, Dynamic AMOLED consistently drew less current than PLS LCD. In idle, dark-mode conditions, AMOLED benefited from pixel-off behavior, reducing current relative to light mode, whereas PLS LCD showed only small variation because the backlight remains on. Full-black screens further highlighted AMOLED's advantage; full-white increased current for both panels, more prominently for AMOLED because all pixels emit, yet AMOLED remained competitive relative to PLS LCD's constant backlight. For text entry, Dynamic AMOLED outperformed PLS LCD across typing, swiping, and speech-to-text at both 79 and 202 characters. Swiping introduced continuous motion and display updates, but AMOLED's per-pixel emission and controller behavior still yielded lower average current. Speech-to-text incurred visual feedback and processing overhead; with airplane mode enabled, recognition ran locally, and AMOLED again consumed less current on average.

VI. FUTURE WORK

We quantified current consumption for PLS LCD and Dynamic AMOLED smartphone displays across baseline states and three text-entry modalities at two message lengths. Dynamic AMOLED consistently reduced current relative to PLS LCD, with average savings reflected as $\sim 30\text{--}35\%$ lower current (equivalently, PLS LCD $\sim 30\text{--}35\%$ higher) and up to $\sim 40\%$ advantage in specific modes. These results support AMOLED-friendly UI choices (e.g., dark themes) and inform device selection where battery longevity is a priority in 5G

contexts. Acknowledging confounders such as panel size, resolution, and SoC differences, future work is necessary to normalize conditions further and broaden workloads to generalize these findings.

Solutions focused on emerging technologies and artificial intelligence are being developed to optimize the energy efficiency of modern displays. Some lines of research may evaluate the power consumption dynamics of 6G-compatible devices. In parallel, prototypes of hybrid displays may be tested, dynamically switching between AMOLED (for dark or static content) and LCD (for high-brightness scenarios) technologies, aiming to optimize visibility in real-world conditions, such as outdoor environments. Other studies may also analyze the durability of adaptive backlight control in LCDs and variable refresh rates in AMOLEDs, ensuring that energy savings do not compromise display lifespan.

Furthermore, Machine Learning and Artificial Intelligence frameworks are being developed to accurately predict user interaction patterns (e.g., touch, voice commands, or typing), enabling proactive adjustments and maximizing energy conservation. Finally, research could also be conducted to evaluate display power consumption in 4K gaming and streaming scenarios, focusing on peak processing loads that reflect real-world usage patterns. It could also examine how heat dissipation during prolonged high-load activities, such as gaming for more than 30 minutes, can affect display efficiency and color accuracy. Investigating the interactions between variable display refresh rates (60 Hz and 120 Hz) and GPU rendering demands during fast-moving content is an area of research worth observing. These efforts would validate the scalability of current findings while addressing next-generation challenges in display technology, sustainability, and user-centric design for 5G/6G mobile network ecosystems.

While our study focused on text-based interactions (typing, swiping, idle states) across 11 scenarios for two display types, we recognize that modern smartphone usage extends to more demanding tasks like gaming and streaming. However, our methodology was deliberately designed to establish a baseline understanding of display energy consumption during fundamental operations, isolating the three scenarios under analysis in this study, which serves as a critical reference for future studies. This focused approach allowed us to:

- Isolate display-specific energy dynamics without confounding variables from GPU/CPU-intensive tasks.
- Provide comparable data for LCD vs. AMOLED efficiency in common low-intensity use cases.
- Establish a reproducible benchmark for future expansion to high-intensity activities.

It should be noted that this work isolates display-related consumption while controlling for operating system background load. Other hardware components, such as CPU, GPU, and memory, are outside the scope of this study but represent opportunities for future extensions. Therefore, future studies will extend this analysis to devices with nearly identical hardware differing only in display technology. In addition, intrusive hardware-level current sensing (e.g., at display connectors) will be applied to validate the virtual profiling method. Further research should also incorporate additional scenarios such as

high-refresh-rate tasks, video playback, and mixed-use cases, enabling a broader understanding of display–interaction energy dynamics.

VII. CONCLUSION

This work introduced a structured methodology to analyze the current consumption of smartphone display technologies under both baseline states and multi-text input modalities. By comparing PLS LCD and Dynamic AMOLED, we showed that user–device interaction patterns play a central role in energy demand, complementing the influence of display hardware itself. The contributions of this study lie not only in the measured results but in the methodological framework: a reproducible approach to display power profiling that integrates baseline control, user interaction scenarios, and non-intrusive measurement. This framework can serve as a reference for future comparative studies on mobile energy efficiency.

This article compares the current consumption and efficiency of PLS LCD and Dynamic AMOLED displays for mobile devices used in 5G mobile networks in various user text input methods and baseline scenarios. By analyzing current consumption during inactive states, swipe inputs, and voice commands, the research shows that Dynamic AMOLED displays consistently outperform PLS LCDs regarding energy efficiency. These findings offer valuable insights for users looking for optimal battery performance and for manufacturers in 5G mobile networks aiming to enhance product appeal through improved display technology. In synthesizing the findings from the analyses conducted, it is clear that Dynamic AMOLED technology consistently outperforms PLS LCD regarding current consumption and efficiency across various user interaction scenarios. The comparative studies show that Dynamic AMOLED excels in several contexts: when the display is inactive, during swipe inputs, and while processing voice input. This superior performance is attributed to its ability to illuminate only the necessary pixels, allowing it to conserve power more effectively than PLS LCD, which relies on a constant backlight. The implications of these findings are significant for both users and manufacturers of mobile devices in 5G networks. For users, the enhanced energy efficiency of Dynamic AMOLED leads to extended battery life, particularly during active device usage. This benefits modern mobile devices, where prolonged operation without recharging is highly valued. Manufacturers can use this benefit by marketing their products with superior battery performance, making them more appealing to consumers. Yet, it is essential to recognize potential exceptions. While Dynamic AMOLED generally outperforms PLS LCD in the examined scenarios, there may be specific situations where PLS LCD offers advantages. For instance, despite its higher current consumption, PLS LCD might provide better visibility in bright environments. Such nuances highlight the importance of considering environmental factors when evaluating display technologies. We quantified current consumption for PLS LCD and Dynamic AMOLED smartphone displays across baseline states and three text-entry modalities at two message lengths. Dynamic AMOLED consistently reduced current relative to

PLS LCD, with average savings reflected as approximately 30%–35% lower current (equivalently, PLS LCD 30%–35% higher) and up to 40% advantage in specific modes. These results support AMOLED-friendly UI choices, such as dark themes, and inform device selection where battery longevity is a priority in 5G contexts. Future work will further normalize conditions and broaden workloads to generalize these findings by acknowledging confounders such as panel size, resolution, and SoC differences.

Based on this article's comparative analysis and findings, some specific improvements can be proposed to reduce power consumption between LCD and AMOLED display technologies. For LCD technology, implementing adaptive backlight control that dynamically adjusts brightness based on content and ambient light conditions can significantly reduce power consumption. Additionally, incorporating local dimming zones to illuminate only active display areas and upgrading to efficient LED drivers with lower idle current can further optimize energy efficiency, addressing its approximately 30% higher average power consumption compared to Dynamic AMOLED. Regarding AMOLED displays, optimizing pixel refresh rates by introducing variable rates tailored to content activity, promoting system-wide dark mode to leverage its pixel-off capability, and processing voice inputs with display sleep modes can amplify its inherent energy savings, which reach up to 40% in standby or reading scenarios.

Cross-technology strategies include developing hybrid display modes that combine the pixel-level efficiency of AMOLED with the brightness advantages of LCD for outdoor use, integrating AI-based power management to predict and adapt to user input patterns, and encouraging collaboration between manufacturers and software developers to incorporate display optimizations into operating system-level power management tools. These improvements can bridge some of the efficiency gaps between both technologies, aligning with the study's findings on input modes and extending the battery life of 5G devices by encouraging manufacturers to refine their products toward sustainable design.

Finally, while this paper provides valuable insights into display power consumption under controlled conditions, it's essential to acknowledge the limitations of non-invasive, virtual measurements. We recommend a physical, hardware-based approach for subsequent research seeking even more granular and accurate power consumption data. This would involve directly measuring current draw from the display components using dedicated instrumentation, potentially requiring disassembly of the DuT. While more complex and resource-intensive, such a methodology would minimize the influence of extraneous variables and provide a more precise understanding of display power dynamics. This direct measurement approach would serve as a crucial validation step for virtual methodologies and enable a deeper investigation into different display technologies' underlying energy consumption characteristics.

REFERENCES

- [1] J. O. De Sousa, R. M. Ribeiro, B. D. M. Pinheiro, and J. J. Arnez, "Power consumption analysis in lcd and amoled display

- technologies for mobile devices," in *2025 IEEE International Conference on Consumer Electronics (ICCE)*. IEEE, 2025, DOI: 10.1109/ICCE63647.2025.10930080, pp. 1–2.
- [2] S.-G. Lim, K. Lee, and Y.-J. Kim, "Mobile amoled display power model considering i-r drop in smartphones," *IEEE Transactions on Industrial Electronics*, vol. 68, no. 3, pp. 2694–2702, 2020.
- [3] J. Chen, W. Cranton, and M. Fihn, *Handbook of visual display technology*. Springer Publishing Company, Incorporated, 2016, DOI: 10.1007/978-3-319-14346-0.
- [4] K. Mikami, "In-plane switching mode liquid crystal display device," South Korea Patent KR100293436B1, Nov. 2003. DOI: 10.1038/s41598-021-90924-x.
- [5] Y. Li, F. You, M. Ji, and X. You, "The influence of smartphone text input method, posture, and environment on user experience," *International Journal of Human-Computer Interaction*, vol. 36, no. 12, p. 1110–1121, 2020. DOI: 10.1080/10447318.2020.1719465.
- [6] S. Ghosh, K. Hiware, N. Ganguly, B. Mitra, and P. De, "Emotion detection from touch interactions during text entry on smartphones," *International Journal of Human-Computer Studies*, vol. 130, pp. 47–57, 2019. DOI: 10.1016/j.ijhcs.2019.04.005.
- [7] A. Rolich, E. Fedotova, and S. Saprykina, "Study of the energy consumption of graphical interfaces on tft displays," pp. 205–210, 2019. DOI: 10.1109/REDUNDANCY48165.2019.9003316.
- [8] A. Prabha, "Power saving and optimization of oled displays for better system design: A survey," pp. 1–4, 2023. DOI: 10.1109/ICIPTM57143.2023.10117875.
- [9] F. Jiang, E. Zarepour, M. Hassan, A. Seneviratne, and P. Mohapatra, "When to type, talk, or swype: Characterizing energy consumption of mobile input modalities," pp. 114–122, 2015. DOI: 10.1109/PER-COM.2015.7146517.
- [10] M. M. Ghaffar, A. Abdullah, J. Younas, V. Rybalkin, J. Ney, P. Lukowicz, and N. Wehn, "efairwrite: Bringing energy efficient text entry to next generation smart devices," *Expert Systems with Applications*, vol. 289, p. 128306, 2025. [Online]. Available: <https://www.sciencedirect.com/science/article/pii/S0957417425019256>
- [11] N. Piechota, K. Skarżyński, and K. Kubiak, "Evaluating the quality of light emitted by smartphone displays," *Applied Sciences*, vol. 15, no. 11, p. 6119, 2025. DOI: 10.3390/app15116119.
- [12] Y. Jin, "Comparative analysis of digital display methods: Lcd, oled and microled," in *IET Conference Proceedings CP895*, vol. 2024, no. 19. IET, 2024, DOI: 10.1049/icp.2024.4020, pp. 426–431.
- [13] M. Ando and M. Yoneya, "Enhanced thin-film transistor driven high-aperture in-plane switching liquid crystal displays without common line and black matrix," *Scientific Reports*, vol. 11, no. 1, p. 11518, 2021. DOI: 10.1038/s41598-021-90924-x.
- [14] J. Jung, H. Park, H. Y. Jung, S. E. Jung, S. G. Kim, T. H. Kim, Y. J. Lim, B.-C. Ku, M. Kim, and S. H. Lee, "Recent progress in liquid crystal devices and materials of tft-lcds," *Journal of Information Display*, vol. 25, no. 1, pp. 121–142, 2024. DOI: 10.1080/15980316.2023.2281224.
- [15] J. O. De Sousa, R. M. Ribeiro, B. De M. Pinheiro, and J. J. A. Arnez, "Power consumption analysis in lcd and amoled display technologies for mobile devices," in *2025 IEEE International Conference on Consumer Electronics (ICCE)*, 2025, pp. 1–2. DOI: 10.1109/ICCE63647.2025.10930080.
- [16] M. A. Fusella, V. M. Menon, and N. J. Thompson, "New physics for better oleds," *IDinformation display*, vol. 28, 2024. DOI: 10.1002/msid.1471.
- [17] P. Dash and Y. C. Hu, "How much battery does dark mode save? an accurate oled display power profiler for modern smartphones," in *Proceedings of the 19th Annual International Conference on Mobile Systems, Applications, and Services*, 2021, pp. 323–335. DOI: 10.1145/3458864.346768.
- [18] Q. Liu and T. Zhang, "P-13.14: Comparison between amoled and traditional display technology and application of amoled," in *SID Symposium Digest of Technical Papers*, vol. 53, no. S1. Wiley Online Library, 2022, pp. 1018–1021. DOI: 10.1002/sdtp.16179.
- [19] J. O. de Sousa, G. C. Fonseca, J. W. A. de Oliveira, and R. N. Santos, "A novel non-invasive method to measure power consumption on smartphones," in *2021 Brazilian Power Electronics Conference (COBEP)*, 2021, pp. 1–6. DOI: 10.1109/COBEP53665.2021.9684072.
- [20] F. Jiang, E. Zarepour, M. Hassan, A. Seneviratne, and P. Mohapatra, "Type, talk, or swype: Characterizing and comparing energy consumption of mobile input modalities," *Pervasive and Mobile Computing*, vol. 26, pp. 57–70, 2016.



Jussif Abularach Arnez holds a Bachelor of Science degree in Telecommunications Engineering, from Universidad Católica Boliviana San Pablo in La Paz, Bolivia, in 2010. He furthered his education by earning a Master of Science in Electrical Engineering and Communications Systems from the Pontifical Catholic University of Rio de Janeiro (PUC-RJ) in 2014. His master's research focused on applying Cognitive Radio technology. In 2019, he completed his PhD in Propagation and Applied Electromagnetism at PUC-RJ, where he conducted

an in-depth investigation into Cognitive Radio networks through advanced computational simulations and laboratory measurements utilizing MATLAB, Python, and C++. His research interests encompass SIP Kamailio server, Software Defined Radio (SDR) technology, and the GNU Radio open-source project. He is a Technical Specialist at the Sidia Institute of Science and Technology, focusing on advancements in 5G and 6G mobile networks and the IP Multimedia Subsystem (IMS). ORCID: 0000-0002-2786-5237.



Rafael Monteiro Ribeiro holds a Bachelor of Science degree in Computer Science, which he earned from Centro Universitário do Norte (UniNorte) in Manaus, Brazil, in 2018. In 2021, he obtained a post-graduate degree in Software Engineering for mobile devices from Centro Universitário Internacional (Uninter). His technical expertise spans from implementing 4G and 5G network protocols to integrating multimedia services in complex environments. Furthermore, he possesses expertise in Android development utilizing the Kotlin programming

language. Rafael works as a Software Developer at Sidia Institute of Science and Technology, focusing on developing and optimizing solutions for 4G/5G mobile networks and the IP Multimedia Subsystem (IMS). ORCID: 0009-0009-1021-9501.



Janisley Oliveira de Sousa holds a Bachelor of Science degree in Computer Engineering, which obtained from the Federal University of Paraíba (UFPB) in 2017. He furthered his education by earning a Master of Science in Electrical Engineering from the Federal University of Amazonas (UFAM) in 2023. He is currently pursuing a PhD in Electrical Engineering at UFAM, where his research investigates software verification and system security using formal methods for embedded systems. His research interests include mainly secure system

architectures, embedded Linux development, battery management systems, and embedded software security in mobile platforms. He is actively engaged in the IEEE community as a member of IEEE Young Professionals and in the IEEE Computer Society (CS), Power Electronics Society (PELS), and Consumer Technology Society (CTSoc). He serves as a Technical Leader in the Embedded Systems Team at SIDIA Institute of Science and Technology. ORCID: 0009-0002-9242-7345.



Maria Gabriela Lima Damasceno holds a Bachelor's degree in Electrical Engineering from the State University of Amazonas (UEA) in Manaus, Brazil, in 2023. Currently pursuing a Master's degree in Computer Science at the Federal University of Pernambuco (UFPE). Her Master's research focuses on Computer Networks, with an emphasis on 5G and 6G network technologies. Her research interests encompass the deployment and improvement of critical communication solutions, ensuring the reliability and efficiency of emergency calls. She is currently

a Software Developer for IMS networks in embedded Android systems at the Sidia Institute of Science and Technology, focusing on advancements in 5G and 6G mobile networks and the IP Multimedia Subsystem (IMS). ORCID: 0009-0009-5586-4053.



Bruno Satiro da Silva holds a technical degree in computer science from the Federal Institute of Rio Grande do Norte (IFRN), in Natal, Brazil, in 2009. Obtained a bachelor's degree in Science and Technology from the Federal University of Rio Grande do Norte (UFRN), in Natal, Brazil, in 2014. Furthered his studies with a master's degree in Electrical Engineering, focusing on Complementary Frequency Selective Surfaces, from the Federal University of Rio Grande do Norte (UFRN) in Natal, Brazil, which he completed in 2017. In 2022, he completed

his doctorate in Electrical Engineering from the Federal University of Rio Grande do Norte (UFRN), specializing in telecommunications and focusing on electromagnetic theory and applied electromagnetism. Previously, he worked as a 5G network engineer and researcher at the Sidia Institute of Science and Technology, in Manaus, Brazil, until 2024. Currently, he is a researcher at the National Institute of Industrial Property (INPI) in Rio de Janeiro, Brazil. ORCID: 0000-0001-8544-4337.



Gidy Carolina Florez Navarro holds a bachelor's degree in Electronic and Telecommunications Engineering from the Autonomous University of the Caribbean (UAC) in Barranquilla, Colombia, in 2009. He furthered his studies with a master's degree in Electrical Engineering, focusing on the development of multiple antennas, from the Pontifical Catholic University of Rio de Janeiro (PUC-RJ), which he completed in 2012. In 2016, he completed his doctorate in Electrical Engineering, focusing on millimeter wave design, at the Pontifical Catholic

University of Rio de Janeiro (PUC-RJ). He contributed to the Magnetism Laboratory of the Brazilian Center for Physics Research and acted as a volunteer representative for several IEEE societies in Latin America. Previously, she was an engineer at the Sidia Institute of Science and Technology, focusing on advancements in 5G mobile networks, in Manaus, Brazil, until 2024. Currently, she works as an NOC analyst in telecommunications in Rio de Janeiro, Brazil. ORCID: 0000-0001-7937-8409.